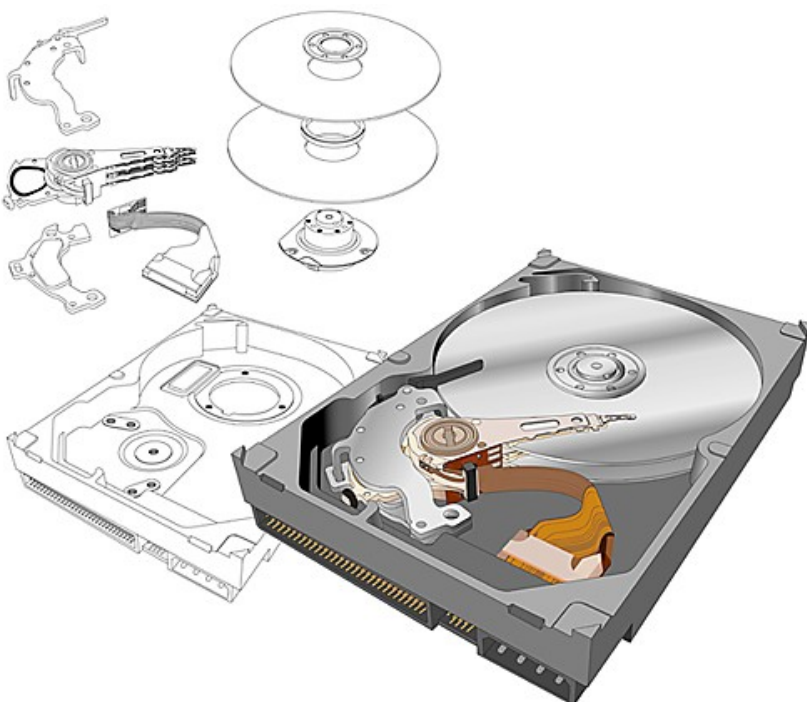
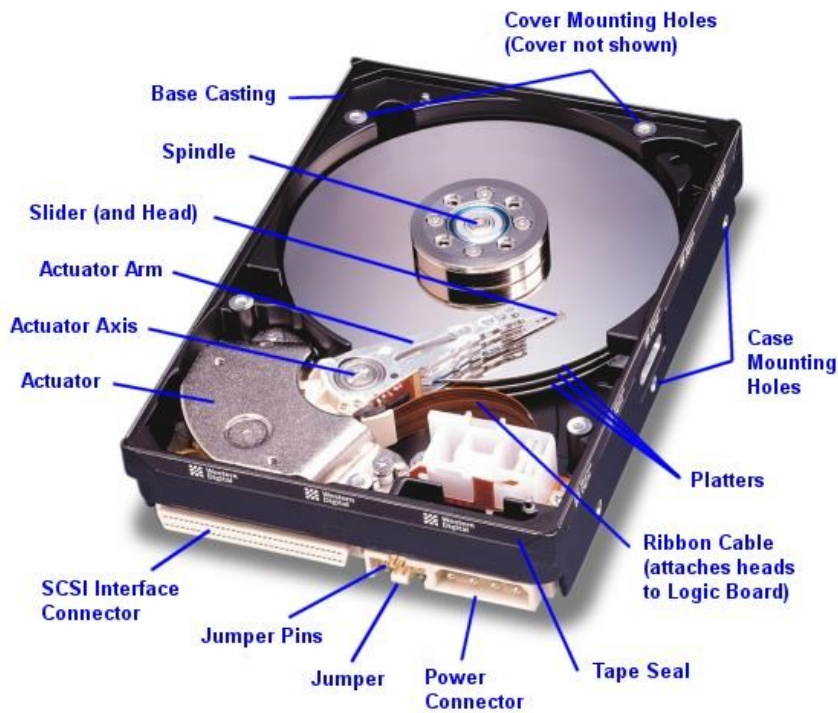
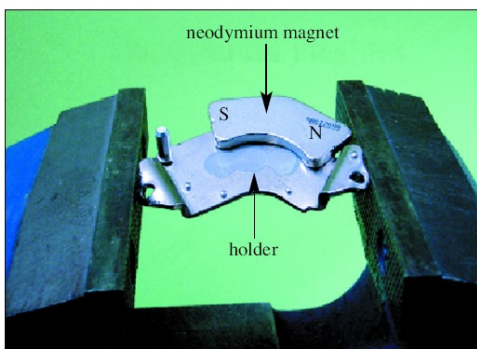
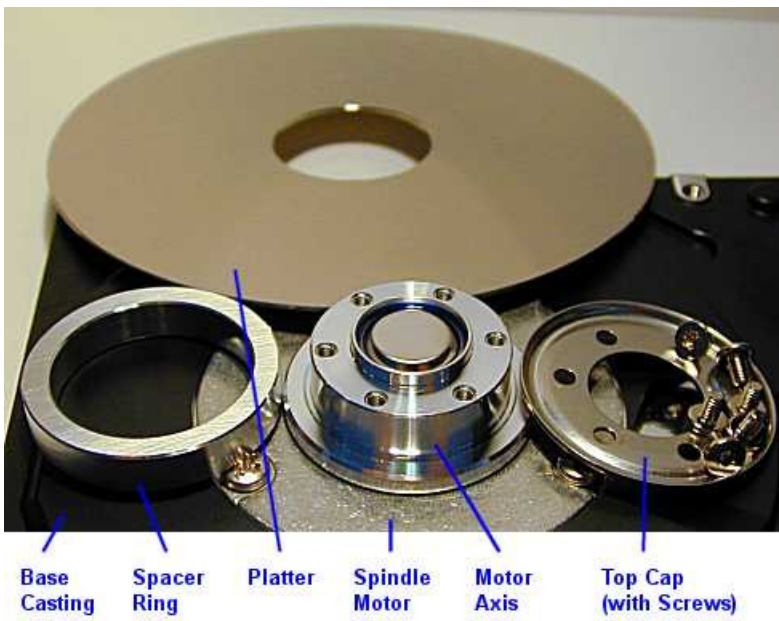


**Anatomía de un ordenador.**  
**Fenómenos y experiencias de física empleando piezas de su despiece**  
Rafael Garcia Molina (rgm@um.es)  
Departamento de Física – CIOyN, Universidad de Murcia

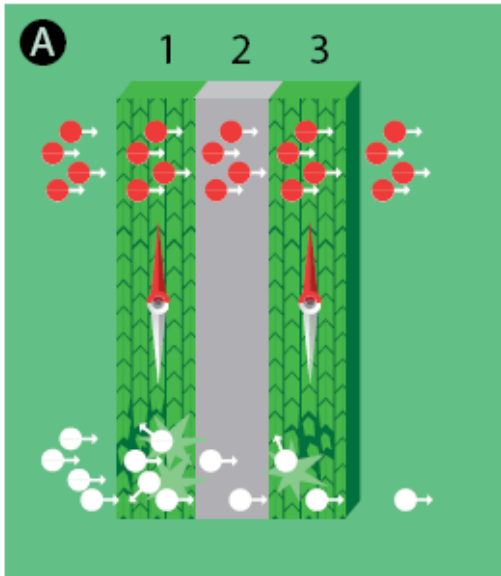
**Páginas web interesantes**

<http://www.pcguide.com/ref/hdd/op/index.htm>  
<http://www.linwei.com.tw/en/knowhdd.html>

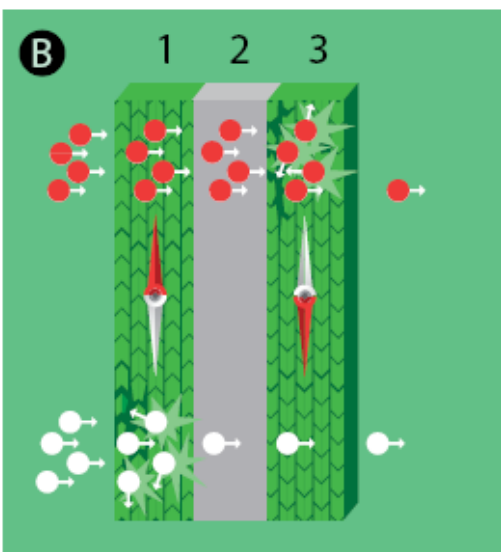




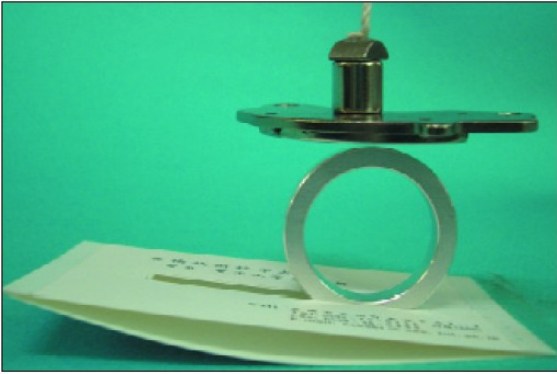
**Figure 2.** The neodymium magnet is removed by squeezing the magnet holder in the jaws of a vice.



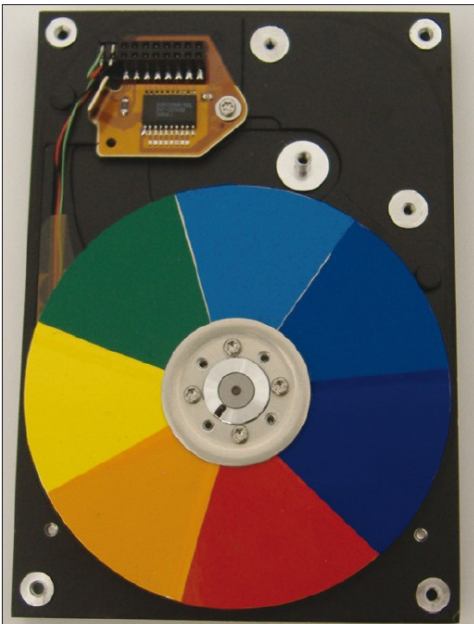
*If the direction of the magnetization is the same in both magnetic layers the electrons with parallel spin (red) can pass through the entire system without scattering to any great extent. The total resistance of the system will therefore be small.*



*If the direction of magnetization in the two magnetic layers is opposed, all the electrons will have anti-parallel spin in one of the layers and will therefore scatter a great deal. As a result the total resistance is high.*



**Figure 3.** A simple, makeshift induction motor.



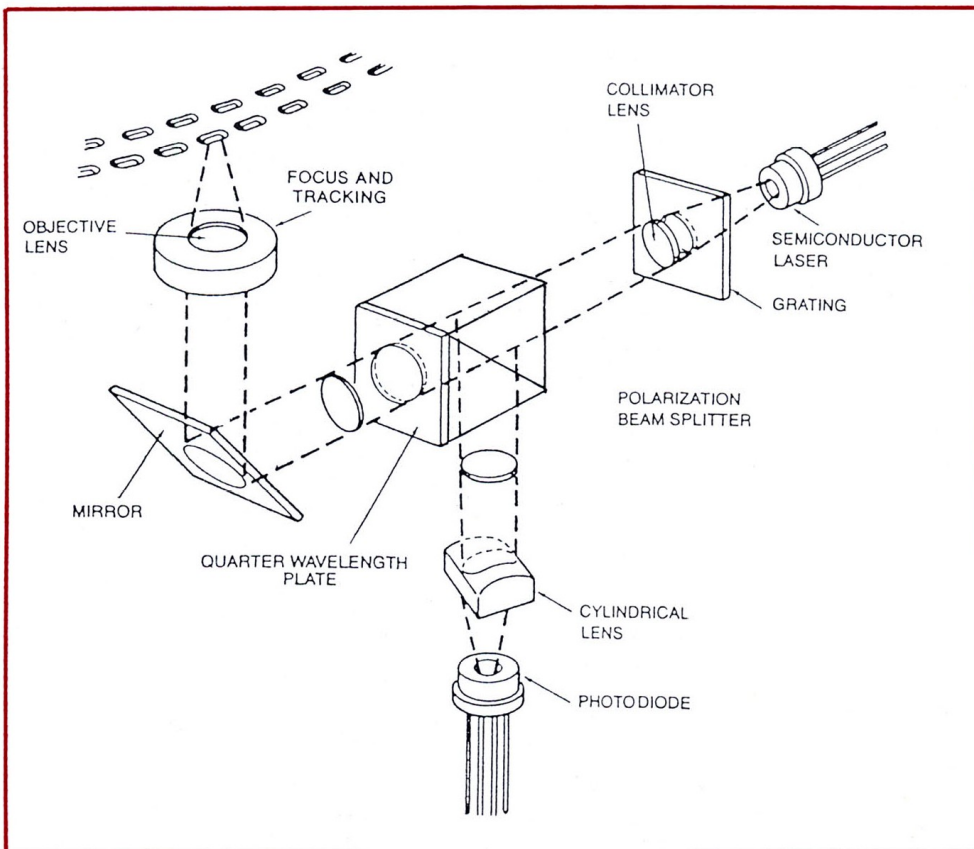
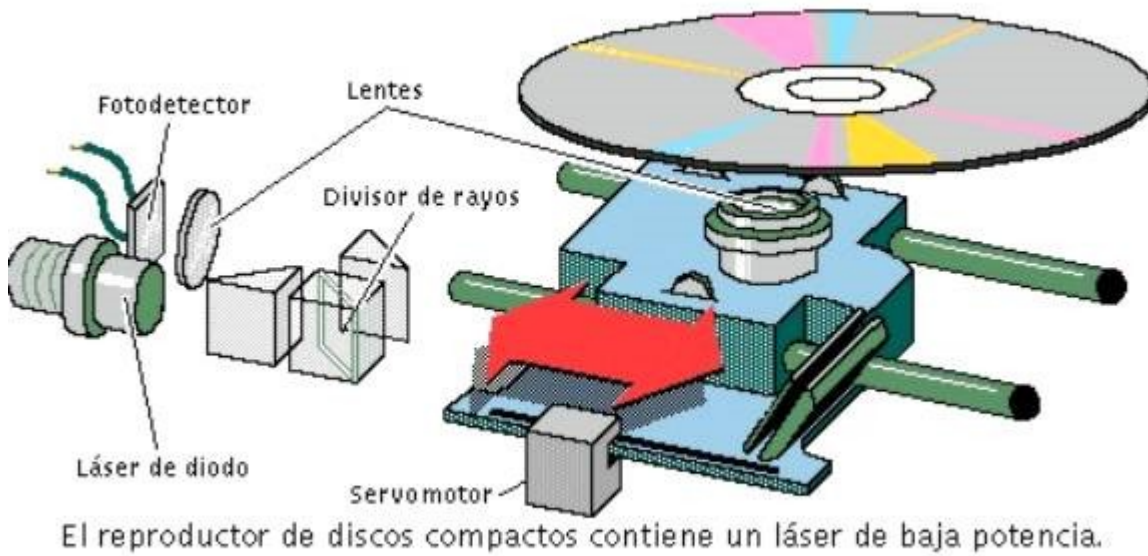
**Figure 1.** The disc at rest.



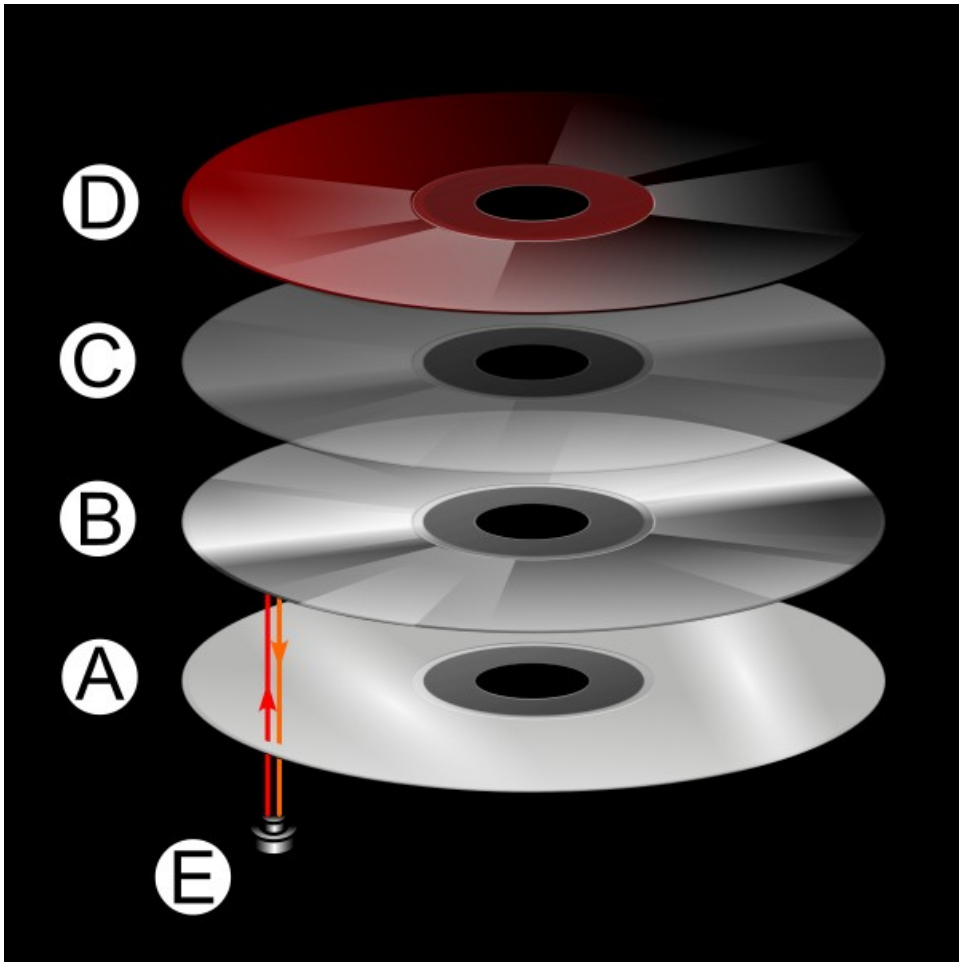
**Figure 2.** The disc on the move.



**Fig. 1.** Levitation of a magnet over the rotating aluminum disk.

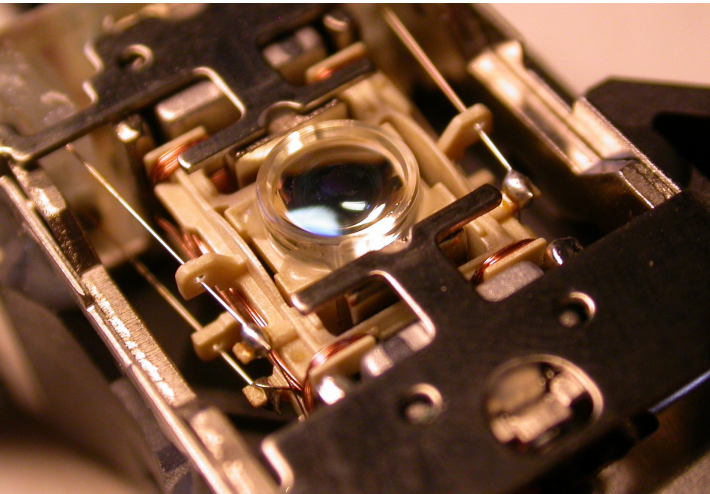
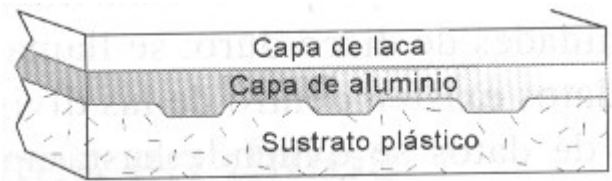


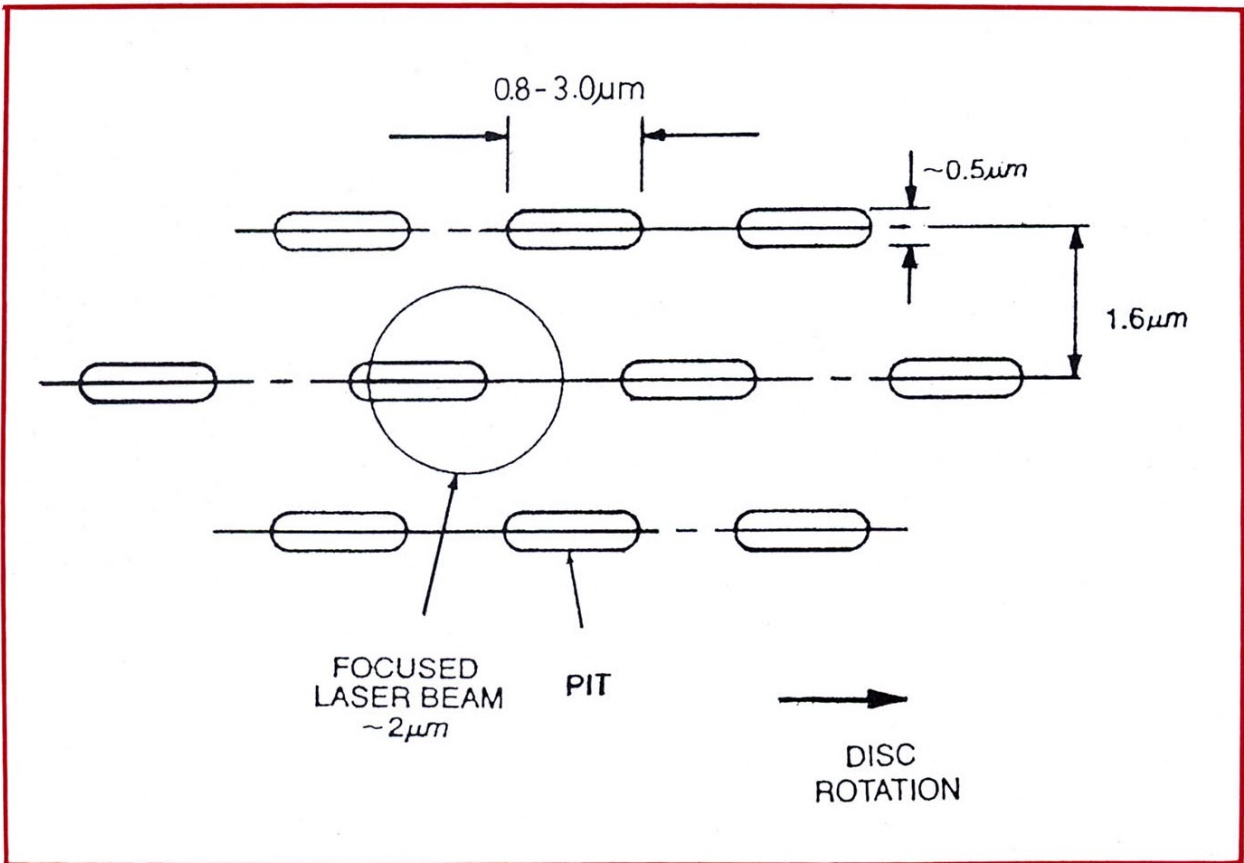
**Fig. 3. Optical pickup in a compact disc player. Coherent light from a semiconductor laser is focused on one recorded track on the disc. The reflected light is directed to a photodiode.**



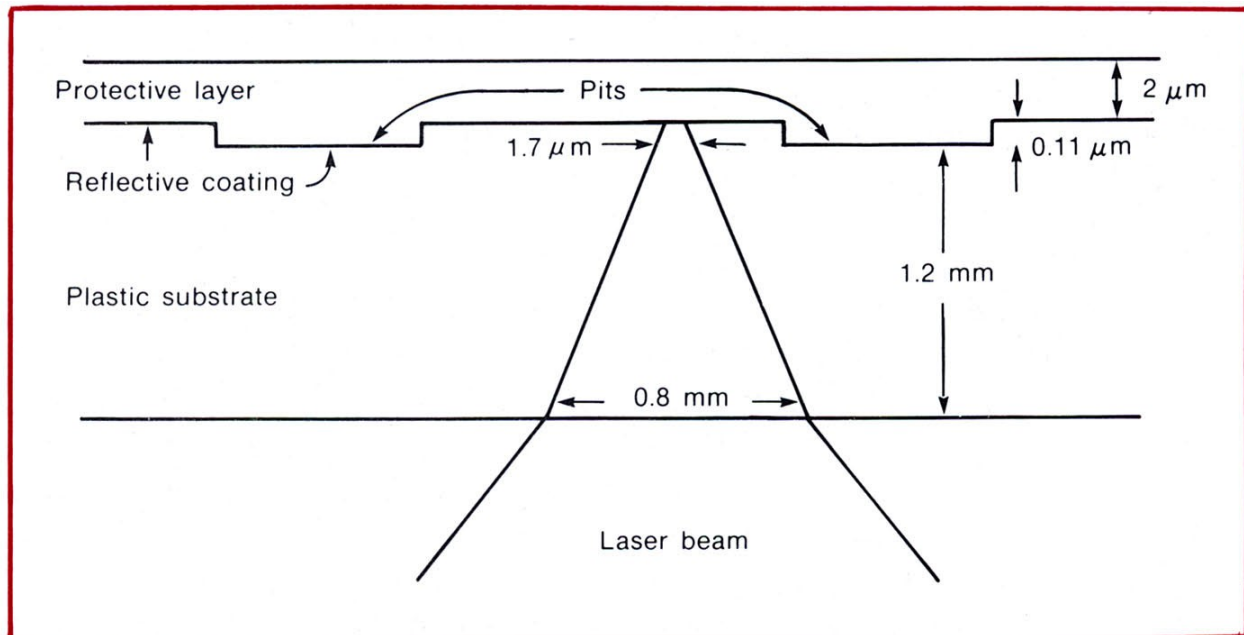
**Diagram of CD layers.**

- A. A polycarbonate disc layer has the data encoded by using lands and pits.
- B. A reflective layer reflects the laser back.
- C. A lacquer layer is used to prevent oxidation
- D. Artwork is screen printed on the top of the disc.
- E. A laser beam reads the polycarbonate disc, is reflected back, and read by the player.





**Fig. 1. Tracks of pits recorded on a compact disc. Also shown is the focused laser beam used to read the recorded information.**



**Fig. 2. Cross section of a compact disc (not to scale).**